

## THE STUDY OF THE REPARTITION OF THE ELECTROMAGNETIC FIELD IN COMPLEX METALIC STRUCTURES

**Claudia-Olimpia STASAC, Dorel-Anton HOBLE**

University of Oradea, 1, Universitatii street, 410087, Oradea, Romania,  
e-mail: [claudiastasac@yahoo.com](mailto:claudiastasac@yahoo.com) , [dhoble@uoradea.ro](mailto:dhoble@uoradea.ro)

**ABSTRACT:** The study of the repartition of the electromagnetic field in complex metallic structures. The topic of the paper is focussed on a study that refers to the distribution of the electromagnetic field in structures achieved out of several materials subjected to the process of warming by inductive measures. The study presented in the paper is meant to be a first stage of a more complex study regarding the use of the inductive heating of the structures made out of different materials and with different constructive forms.

**KEYWORDS:** electromagnetic field, metallic structures, inductor, inductive heating, dyscredization network

### 1. INTRODUCTION

In essence, the electromagnetic field can be considered conceptually, as being a physical form of existence of the matter, constituted out of two components, namely: electric field and magnetic field. The electric field is produced out of electrized bodies or by the variation in time of the magnetic field and is characterized by the intensity measures of the electric field  $E$  and electric induction  $D$ . The magnetic field appears in magnetized bodies, around the electrized bodies in motion, or at the variation in time of the electric field, this being characterized by the measures of intensity of the magnetic field  $H$  and magnetic induction  $B$ .

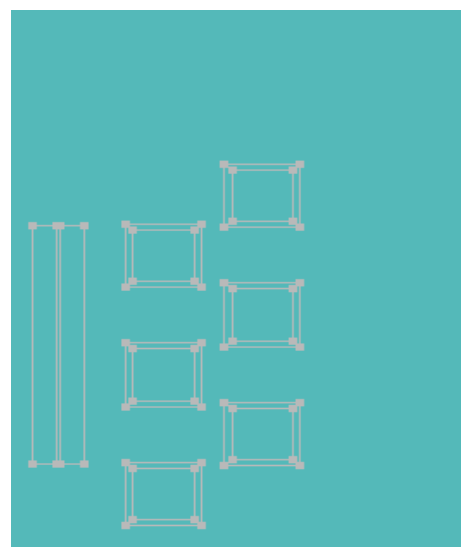
Knowing the electric and magnetic field, their spatial repartition of these constitute the premise of a calculation of the global performances in any functioning regime.

By the numeric modelling of the processes there can be estimated with sufficient precision the values of the measures of the field resulting following the imposing of certain conditions with regard to the geometric form of the device studied, the materials used, or there can be determined the response of the equipment to the variation of certain parameters: power supply, material, etc.

All these data are of great use in projecting (design) with the condition that the errors between the values calculated on the model and those measured on a real system to be sufficiently small and the model to be experimentally validated.

### 2. PRESENTING THE PROBLEM OF STUDY

For the study effected in this paper, there was considered an ensemble formed out of two pieces of the form of regular straight prisms, empty inside and assembled coaxially, among which there is placed a third material, the structure of the piece being presented in the figure no. 1. The interior element is made of brass and the exterior one of iron whereas the intermediary one of tin. The two materials, interior and exterior respectively, were chosen out of the wish that the study enables a subsequent development towards the technologies of combining the hybrid structures, using the electromagnetic processing.



**Fig.1 The field of study**

The technology of combining the three materials is based on heating the exterior structures up to a certain temperature after which the power supply of the inductor is stopped, the transfer of the heat towards the interior of the assembly, there being achieved a phenomenon of thermal conduction.

Due to the different dilatation coefficient, there appears a force of pressing the interior structure towards the exterior structure, which in case of a well-controlled process, leads to the structural combining of the three materials.

The local form of the general laws of the electromagnetic field in structures characterized by continuous and uniform environments from the point of view of the physical properties, have the form:

- the law of electromagnetic induction:

$$\text{rot}E = -\frac{\partial B}{\partial t}$$

- the law of magnetic circuit:

$$\text{rot}H = J + \frac{\partial D}{\partial t}$$

- the law of conserving the electric charge:

$$\text{div}J = -\frac{\partial \rho_v}{\partial t}$$

- the law of electric flux:  $\text{div}D = \rho_v$

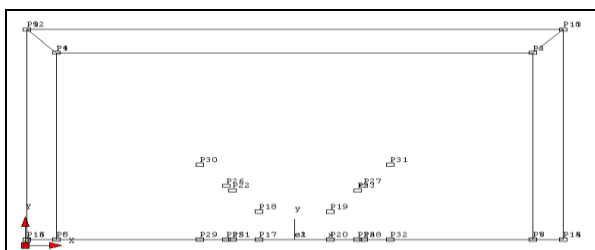
- the law of conserving the magnetic flux:

$$\text{div}B = 0$$

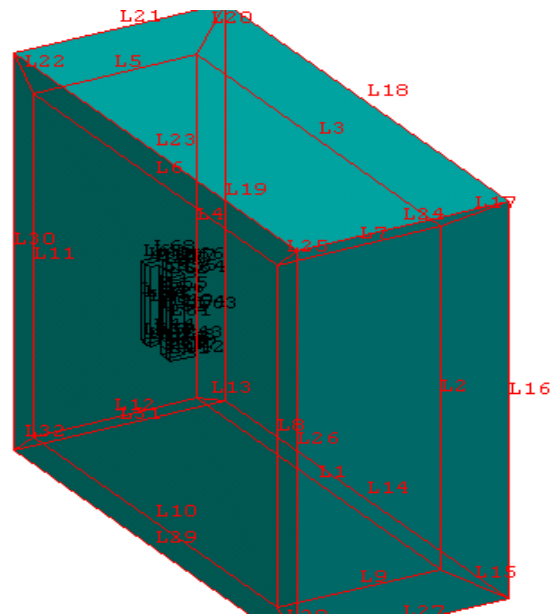
### 3. BUILDING THE GEOMETRY AND THE NETWORK OF FINITE ELEMENTS

The main stages in building the geometry of the field of calculation are presented in figure 2 (a,b,c) the classical procedure presupposing the construction of the points, then the lines and the regions of surface type.

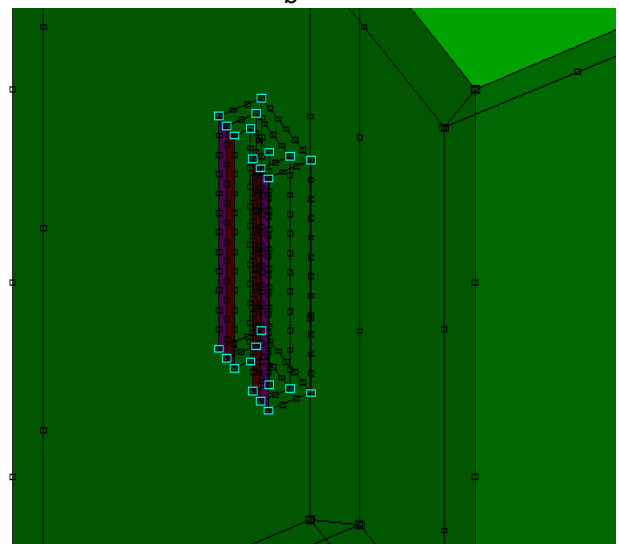
In the algorithm of automatic dyscretization, the initial front is built based on the basis of dyscretization the border given by the user, then building more and more regular elements as regular as possible, it is progressed towards the interior of the domain with each new stratum created.



a



b

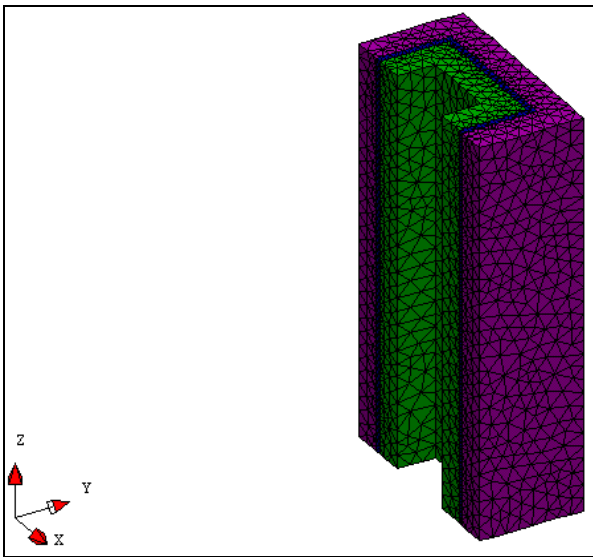


c

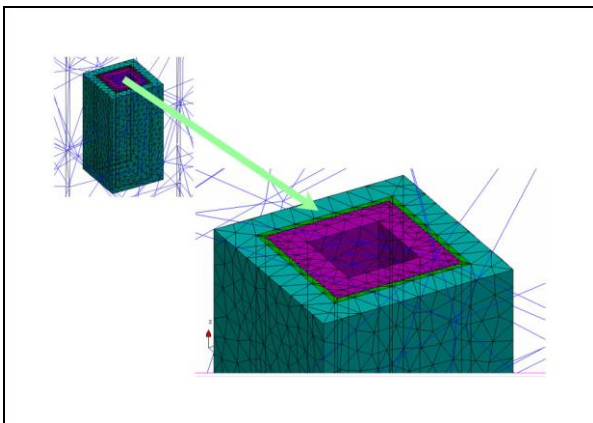
**Fig. 2 Stages in building the geometry of the domain of calculation**  
**(a) numbered points,**  
**(b) extruded lines and points, (c) facets**

The dyscretization network in finite elements of the calculation domain is exclusively built of triangles, the maximum finesse of it corresponding to the areas of maximum interest in the study.

Figure 3 presents the dyscretization network in the structure studied and figure 4 presents the dyscretization network of the whole field of study.

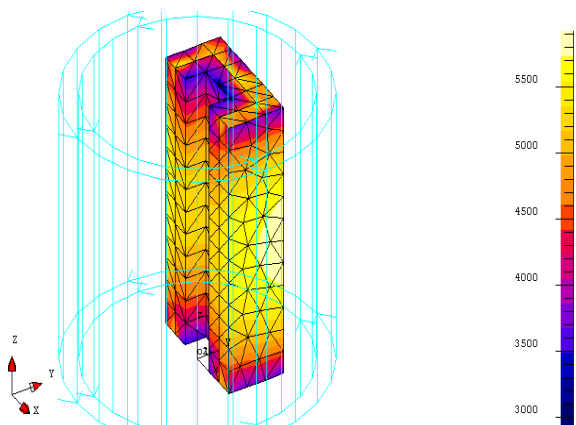


**Fig.3. The dyscretization network of the structure studied**



**Fig.4. The dyscretization network of the whole field of calculation (a); detail (b)**

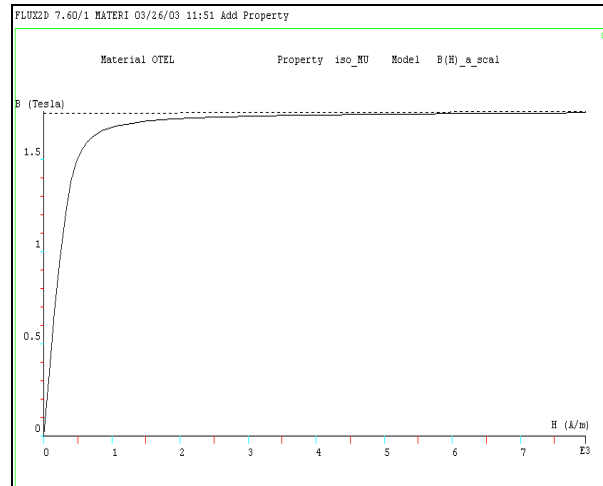
Modelling the inductor that envelops the structure achieved out of the three materials is presented in figure 5.



**Fig.5. Modelling the envelopments of the inductor**

From the point of view of the properties of the material, in this stage of the study there presents interest the magnetization curve of

the material of the external device of the ensemble, i.e. steel, presented in figure 6. The value of the magnetic saturation induction is  $B_s = 2T$  and of the magnetic relative permeability is 1500.

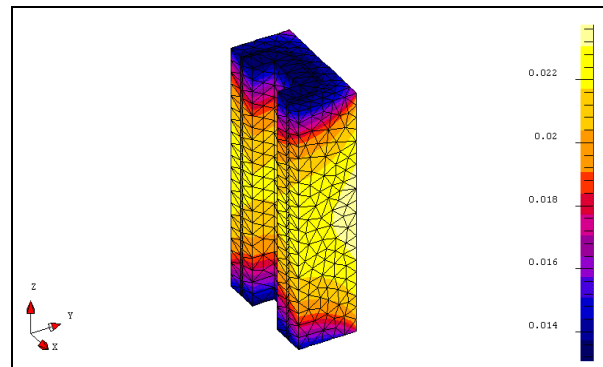


**Fig.6. The variation curve of the induction, function of the intensity of the magnetic field for steel**

#### 4. THE NUMERIC MODELLING

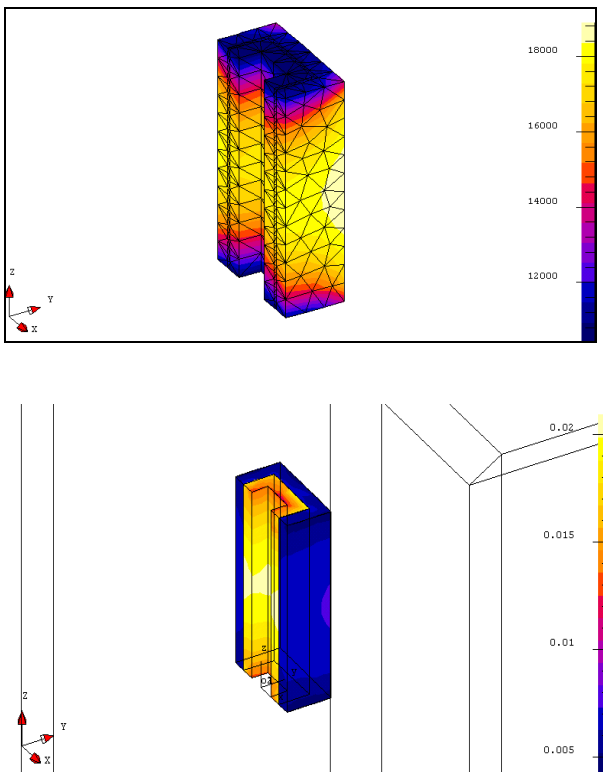
In order to achieve the numeric modelling, there was used the program of modelling and simulation FLUX3D and there were imposed as entry (input) data a tension on the inductor of 80 V and the work frequency being of 2500 Hz.

Further to the electric simulation, there was studied the repartition of the density of the electromagnetic field in the structure formed out of the three materials, the result of the simulation being presented in figure 7.



**Fig.7. The density of magnetic flux**

In the following figure (Fig.8) there is presented the distribution of the intensity of the magnetic field in the structure formed of the three materials.



**Fig.8. The intensity of the magnetic field**

### 5. CONCLUSIONS

The paper presented above is meant to be a first step in the study of the behaviour of the structures achieved of materials having different properties, during the inductive processing of these. Based on the results obtained the study can be continued during the optimization of the phenomena of electromagnetic conversion in processes of inductive heating of such structures, by modifying certain and various constructive or functional parameters of the structures studied.

In the present paper there was analysed the heating by turbionary currents and the dilatation of the exterior tube in view of achieving the difference of temperature necessary to the procedure of fitting with a ferrule. The field of temperatures in the spare part was obtained by sorting out the problems

coupled by quasi-stationary electromagnetic field and by thermal diffusion. The heating is done at a sufficiently high temperature, so that the dilatation to lead to such a discrepancy of diameters which should enable the introducing of the inner tube into the exterior one, even if during the manoeuvres, the temperature of the tube (pipe) decreases. Again, it must be outlined that the main difficulty of the problems consists in the fact that, wishing to obtain a sufficiently high temperature, the Curie point is exceeded, in the case of the ferro-magnetic spare parts, this implying a strong dependency on temperature of the constitutive relationship B-H. Moreover, this dependency is non-linear

### BIBLIOGRAPHY

1. J.C. BOURHIS : "Chauffage de billettes par inducteur multicouche : Du prototype a la premiere reference industrielle"- *Les cahiers de l ingeniery* , No 62 , 1996 ;
2. D. HOBLE , Claudia, STAŞAC : "Study about the inductive heating of a cylindrical workpiece , used torsioned inductor" – *Proceeding of HIS-01 , Padua , Italy, 2001;*
3. D. HOBLE : "Numerical modeling and experimental validation of a inductive heating process with a doublelayer inductor." – *The 10<sup>th</sup> International IGTE Symposium on Numerical Field Calculation in Electrical Engineering, - Graz, Austria, 2002;*
4. D.HOBLE, Claudia, STASAC : " Study about the increasing of the heating efficiency of the coaxial bimetallic workpieces" -" *Proceeding of International Conference of Central European Energy , Efficiency and Renewable Energy Sources – Prague 2003;*
5. A. Fontanet: *Flux 2D, Flux 3D – Tools for induction heating modeling*, Cedrat Recherche, France, 1996;
6. \*\*\* CEDRAT " Flux 3D, versiunea 3.3 "CAD Package for Electromagnetic and Thermal Analysis using Finite Elements", France, 1999.